



GKB

THE WORKER IS KING



Quick-Brush

Manual_Quick-Brush_EN_2302

QB200

EC DECLARATION OF CONFORMITY CONCERNING MACHINES
According to Directive 2006/42/EG, annex 2, point 1, A

GKB Machines B.V.
Middelweg 1
2992 SP Barendrecht
Nederland

hereby declares that the

GKB Quick-Brush

Type: QB200

to which this declaration relates are in conformity with the provisions of:

- Directive 2006/42/EC Machinery Directive

At Barendrecht, 13/02/2023



T.J.W. Kraaijeveld

UKCA DECLARATION OF CONFORMITY CONCERNING MACHINES
According to Machinery (Safety) Regulations 2008

Manufacturer:
GKB Machines B.V.
Middelweg 1
2992 SP Barendrecht
Nederland

UKCA Delegate
GKB Machines Ltd.
Warwick House, Ermine Buseniss Park, Spitfire Close
Huntingdon PE29 6XY
United Kingdom

hereby declares that the

GKB Quick-Brush

Type: QB200

to which this declaration relates are in conformity with the provisions of:

- Machinery (Safety) Regulations 2008

At Barendrecht, 13/02/2023



T.J.W. Kraaijeveld

TABLE OF CONTENTS

1.	FOREWORD.....	5
2.	INTRODUCTION	5
3.	CONTACT	5
4.	WARRANTY	6
5.	SAFETY	6
5.1.	General	6
5.2.	Safety instructions	7
5.3.	Product specifications Quick-Brush	8
6.	CONSTRUCTION OF THE QUICK-BRUSH.....	9
6.1.	The frame	9
6.2.	The brushunit	9
6.3.	The rake	9
6.4.	Height adjustment.....	9
6.5.	Rubber rag	9
6.6.	The result.....	9
7.	OPERATION QUICK-BRUSH	10
7.1.	Connecting and disconnecting the machine.....	10
7.2.	Start brushing	11
7.3.	Transport and storage.....	11
8.	MAINTENANCE	12
8.1.	Maintenance schedule	12
8.2.	Lubrication scheme	13
9.	FAILURES.....	14
10.	END OF LIFE	14
	ANNEX I TIGHTENING TORQUE	14
	ANNEX II RISK ANALYSIS	15
	ANNEX III SAFETY STICKERS.....	16

1. FOREWORD

The information contained within these operating instructions covers the necessary use, safety, operation, and maintenance of the machines mentioned in the CE declaration. Before operating anyone of the machinery has to read this operating manual in its entirety. The manufacturer will not be held liable for an injury or damage which occurs from improper use.

It is the goal of the manufacturer to create excellent products, therefore we hold the right to make changes at any time and will not be held under obligation to previously delivered machines. Certain aspects, such as weight and dimensions, may change at any time without notice. Images are also not bound to interim changes.

All rights reserved.

2. INTRODUCTION

The Quick-Brush is designed to equalize artificial grass fields after the field has been worked. Brushing regularly reduces drainage issues and keeps the sports technical attributes in perfect condition. The infill material is worked upwards using brush bars, after which it is equally distributed across the field. The Quick-Brush is tailored to any consumer's individual needs.

Every machine is marked with a code, as seen in the image below.

Example:

Model 'QB200':

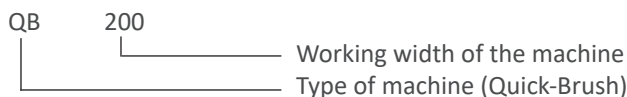

The manufacturer shall not be held liable for any damage resulting from unintentional use.

3. CONTACT

Manufacturer:

GKB Machines B.V.
Middelweg 1
2992 SP Barendrecht
NETHERLANDS
info@gkbmachines.com
www.gkbmachines.com

Productnumber Manual: See footer/ front page

Your personal Dealer:

Your GKB dealer:

4. WARRANTY

The statutory warranty period of two years from the invoice date applies to the machines. Warranty repairs or product replacements do not extend the warranty period of the machine or parts. The guarantee does not apply to items arising from normal wear and tear or ageing.

A warranty procedure starts with an investigation to determine whether the problem is covered by the warranty. Your cooperation is required to verify that the warranty conditions have been met. To this end, keep a record of the maintenance and repairs carried out in a maintenance logbook.

If the manufacturer receives a warranty notification, it will be determined whether the defect is covered by the warranty. If this is the case, a suitable solution will be found in consultation with the customer. In all cases, consult with the dealer before you try to solve the problem yourself. Warranty can only be given if the machine is in its original condition.

The manufacturer's written permission is required to ensure that the machine does not deviate in any way from the aforementioned purpose of use. Use other than as described will lead to the loss of product liability and warranty.

Product liability obliges the manufacturer and the dealer, when selling machines, to provide a manual and to instruct the user on the operating, safety and maintenance instructions.

The manufacturer is not responsible for any (unintended) damages to grass or sport fields.

Caution! The operating instructions must also be supplied if the machine is subsequently exchanged or resold by the user. Also inform the new user of the regulations.

5. SAFETY

5.1. General

The safest operation requires these machines are operated exactly according to these instructions. In addition, there are also safety warnings on the machines to warn of potential dangers and instructions on how to handle them. The only way to 100% guarantee no property damage or personal injury occurs is to follow these instructions. While using this machine, keep this handbook nearby and always ensure that safety markings on the machines are visible.

Any local safety regulations, including road traffic regulations, must be observed at all times.

The warranty, CE marking, and product liability automatically expire upon changes being made to the machine without consultation of the manufacturer.

The machine is equipped with several safety stickers, to instruct the user how to handle the machine with care. An example of a safety sticker is shown next.

Annex III describes every type of safety sticker. Read them carefully before using the machine.



5.2. Safety instructions

1. These operating instructions must be read and understood by everyone who works, checks or maintains the machine in order to avoid risks and to avert dangers.
2. Pass on all safety and operating instructions to all users.
3. The machine may only be used for the intended work.
4. For optimum performance, the surface to be worked on must be flat and free of obstacles.
5. Only use parts and accessories specified by GKB. The installation and/or use of non-original parts and accessories may change or impair the specific characteristics of the machine. GKB is excluded from any liability for damage resulting from the use of non-original parts and accessories.
6. Before working with the machine, it is necessary to become familiar with all control components, their functions, safety aspects and risks. The machine may therefore only be operated and maintained by qualified personnel.
7. Maintenance must be carried out in accordance with the instructions in the manual. The maintenance carried out must be recorded. Never come under the machine in any situation!
8. Before commissioning, the safety of operation and transport must be checked. The inspection includes, but is not limited to, the correct functioning of the mechanical, hydraulic and electrical components.
9. If leaks are suspected, stop the entire hydraulic system and allow it to cool down before carrying out maintenance.
10. Before use, check that there are no persons and/or obstacles within the working area of the tractor and the machine.
11. There are several warning labels on the machine. These stickers contain important instructions for safe use and must always be clean and visible.
12. All safety devices must be attached to the machinery and be in good working order. Timely replacement of worn and damaged protective equipment is required. This also applies to the warning labels. Fixed guards must always be present during operation.
13. The operator's clothing must be close-fitting. If necessary, wear head and hearing protection.
14. Driving on the machine during work and transport is not permitted.
15. When using the machine on public roads, the (local) traffic regulations of the respective country apply. Observe the markings, lighting and safety devices applied. Only drive if all required permits and approvals have been obtained.
16. Maintain an adjusted speed when the machine is hanging behind the tractor. Especially when driving over thresholds or poor road conditions. Always place the topline in the round hole!
17. The driver is responsible for ensuring that the tractor and the machine are on public roads in accordance with the regulations. Permitted axle loads and weights must be considered.
18. If the driver is unable to oversee the carriageway immediately behind him, he must be instructed when reversing. Instructors must be within the driver's field of vision only and never between the tractor and the machine.
19. Connect the machine with the tractor according to prescribed tools.
20. When connecting and disconnecting, parking or storing the machine, it must be prevented that the machine moves unintentionally. Depending on the machine, this can be prevented by applying the brakes, using the parking position or locking the wheels by placing wedges.
21. During use, transport or storage on a sloping slope or during maintenance, one should be aware of the risk of tipping over.
22. Prevent burns by careful use of hot components such as oil lines and engines. When carrying out maintenance work, allow the system to cool down completely.
23. It is not allowed to drive or maintain the machine under the influence of medication, drugs or alcohol.
24. Using headphones or hearing protection with music or radio is not permitted.
25. Smoking and open fire is prohibited in and around the machine.

5.3. Product specifications Quick-Brush

	Unit	QB200
Dimensions		
Working width A	cm	200
Length brushframe B	cm	70
Total length C	cm	90
Height D	cm	100
General specifications		
Empty weight	kg	60
Specifications towing vehicle		
Power	pk	25-45

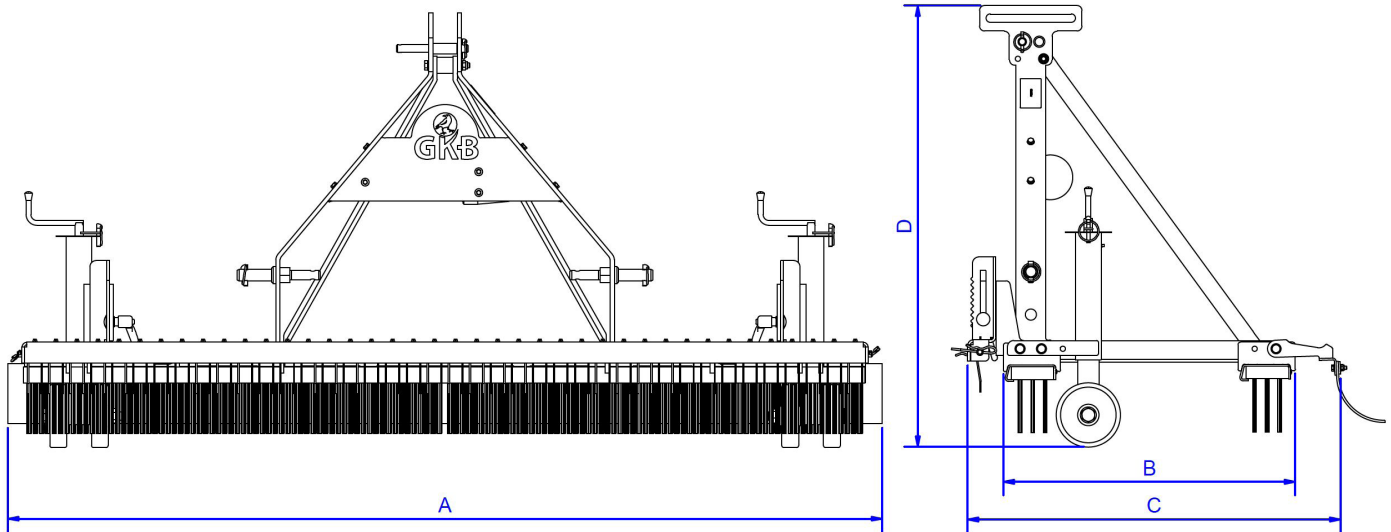

6. CONSTRUCTION OF THE QUICK-BRUSH

A Quick-Brush has many different components and parts. This chapter describes each of them.

6.1. The frame

The hitch of the Quick-Brush forms the basis for the different components of the machine. The three-point hitch connects the machine to the towing vehicle.

6.2. The brushunit

The brush unit comprises a frame with two plastic brush bars. The frame is secured at the hitch using four points and can be adjusted horizontally using the top shaft of the towing vehicle.

The plastic bars are pushed into the frame profile and are held together with clamps. When the hairs have worn down, the entire plastic bar needs to be replaced.

6.3. The rake

Using rapeseed teeth the turf fields are roughly aerated prior to brushing the infill material. The steel teeth are adjustable in height. The toothsets are provided with a springs to guarantee a longer lifespan.

6.4. Height adjustment

For creating an equal top layer two support wheels are applied. The wheels can be adjusted in height using spindles. In combination with the top bar of the towing vehicle the machine needs to be positioned horizontal.

6.5. Rubber rag

To prevent dust formation and unwanted accumulation of infill material, a rubber drag mat is applied. This mat is mounted on the rear side of the frame and rests entirely on the field.

6.6. The result

The result is a brushed field, where potential drainage issues have been fixed. Moreover, brushing the field will optimize the sports technical attributes.

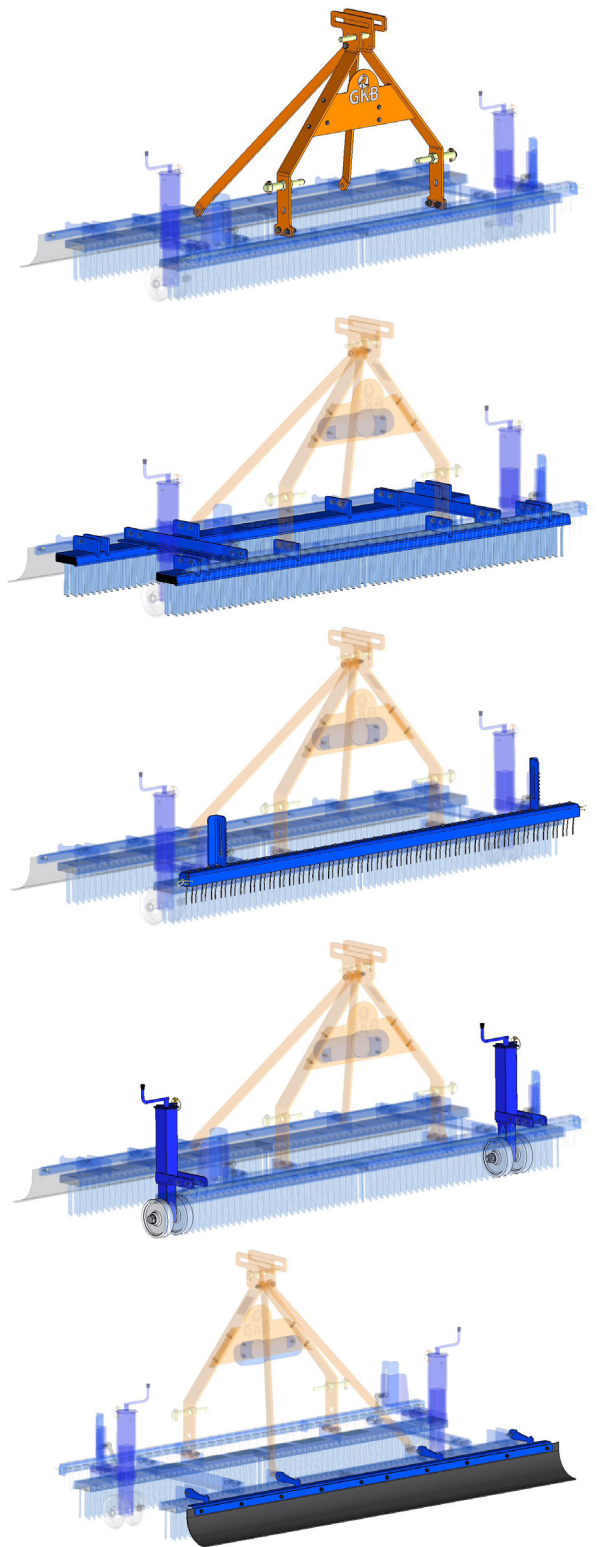

7. OPERATION QUICK-BRUSH

7.1. Connecting and disconnecting the machine

The following steps describe how to connect and disconnect the Quick-Brush.

Connecting:

1	Make sure that the tractor and machine are both placed horizontal and in line;
2	Connect the machine to the three-point hitch of the tractor and secure the attachment points with the locking pins;
3	Lift the machine and check if the distance between the machine and ground is equal on the left and right side. If necessary, change the positions of the adjustable stabilizer arm;



Zie risicoanalyse: Zandstrooier/ omgeving machine

Disconnecting:

1	Make sure that the tractor and machine are both placed horizontal and in line; Remove infillmaterial before leaving the field.
2	Lower the machine slowly until it completely rests on the ground; Disconnect the tree-point hitch and move the tractor.



Zie risicoanalyse: Zandstrooier/ omgeving machine

7.2. Start brushing

- 1 Position the Quick-Brush at the desired height. If necessary, change the height of the toothbrush or support wheels. Adjust the topline to position the machine horizontal;

Always ensure that the machine can't move and is switched off.



- 2 Start driving and brush for a couple meters.

- 3 Stop brushing, lift the machine and switch the tractor off. Check if the desired depth is reached and if the entire surface is brushed equally. If not, change the height by adjusting the spindles or the adjustable stabilizer arm of the tractor;

Pay attention, never come under the machine!

 Zie risicoanalyse: Zandstrooier/ omgeving machine

7.3. Transport and storage

Transport:

When transporting the machine, a suitable means of transport must be selected. Make sure that the machine is secured against rolling away and tipping over. If you don't have sufficient knowledge for a transport, carry it out by a specialised transport company. Provide at least four attachment points on the transporting vehicle.

Storage:

The following points must be taken care when storing the machine:

1. Before storage, clean the machine in such a way that no sand or other impurities are left behind;
2. Store the machine at a dry place;
3. Check if the machine is positioned right with the support legs or place wheel chocks in front and behind the wheels;
4. Never put the machine away on the brake (if applicable);
5. Empty the tanks of the machine if they are filled with water;
6. To prevent corrosion of uncoated parts, apply a protective oil layer;

If the machine is to be used again after storage, all maintenance points must be gone through. Before use, make sure that all components are working properly.

Lifting:

The machine may only be lifted at the designated attachment points. It is important that all existing attachment eyes are used to lift the machine safely. Attaching lifting equipment to other parts of the machine can cause serious damage to the machine and the environment. Make sure the machine is free of materials such as infill and seeds.



8. MAINTENANCE

8.1. Maintenance schedule

To maintain machine quality, adhere to the following diagram. The list of spare parts will show the correct parts to replace.

Always ensure that the machine is switched off, cannot move and has cooled down completely.

		Operating hours					
		Before use	50 h	250 h	500 h	1000 h	Annually
General	Outside cleaning of the machine	x					
	Check if all safety stickers are on the machine	x					
	Check state of wearing parts for broken pieces or deformation	x					
Others	Check locking pins	x					
	Tighten bolted connections of rotating parts		x				
	Tighten bolted connections of fixed parts			x			

8.2. Lubrication scheme

For optimum machine performance, please refer to the plan below for lubrication of the maintenance points.

		Operating hours					
		Before use	50 h	250 h	500 h	1000 h	Annually
EP2 grease	1 Lubricate hinge points of the cylinders			x			

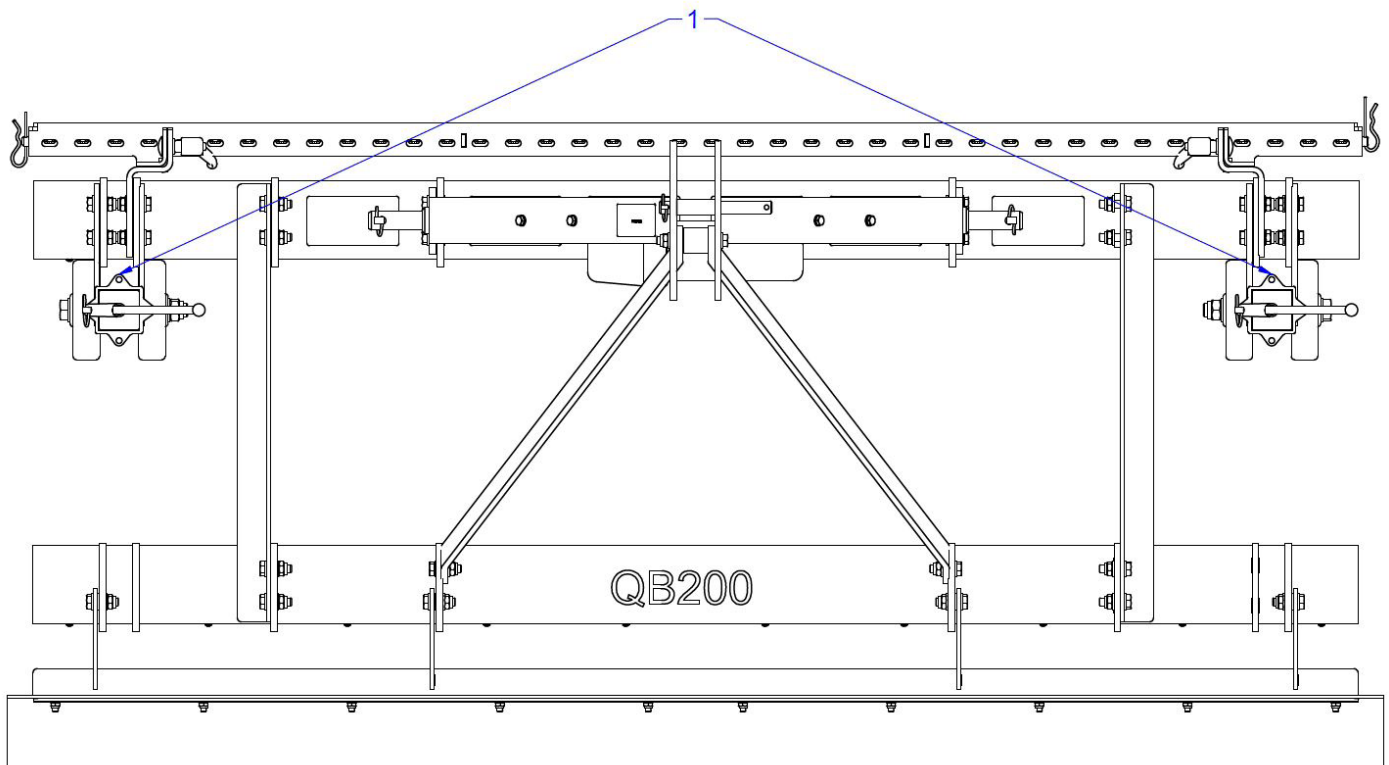

9. FAILURES

If a failure is detected, please go through the following points before contacting your dealer.

Frasing result		
Symptom	Cause	Solution
The result isn't equal	The driving speed is too high	Decrease the driving speed
	The dragframe doesn't rest entirely on the ground	Lower the entire machine
	The machine isn't placed horizontal	Position the machine by adjusting the spindles
	Inequalities in the field	The material is stick to the ground or the field is not equal

10. END OF LIFE

To dispose of a machine, follow all local regulations. Practice appropriate safety measures.

Follow these steps:

1. Decommission the machine and shut it down hydraulically;
2. Drain and recycle all consumables;
3. Dispose of the machine in accordance with the local regulations.

ANNEX I TIGHTENING TORQUE

When tightening bolts, observe the following maximum torques (ISO898/1).

The following types of bolts are used in the machine:

- Bolts for wear parts (chisels, etc.): 10.9
- Other bolts: 8.8

		Tightening torque [Nm]	
		Bold strength:	
			8.8
			10.9
Metric	M5	6	8,5
	M6	10,3	14,7
	M8	25,5	35,3
	M10	50	70,6
	M12	87,3	122,6
	M14	138,3	194,2
	M16	210,8	299,1
	M20	411,9	578,6
	M24	711	1000













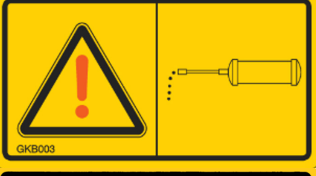

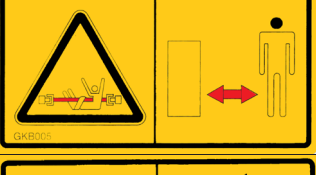
ANNEX II RISK ANALYSIS

Based on risk analyses, measures were taken during the development of the machines to ensure the safety of users and bystanders. These results include, but are not limited to, the following measures:

Item	Risico	Wanneer	Risico reductie
Frame quick-brush	Crushing injuries when connecting the machine to the tractor	If a bodypart comes in contact with the connection points	Safety stickers placed Safety instructions in manual
Support wheels	Crushing injuries in between parts of the support wheels	If a person turns the wheels in or out	Safety stickers placed Safety instructions in manual
The rake	Crushing injuries in between parts of the rake	If a person moves the toothsets up or down	Safety stickers placed Safety instructions in manual
		If a toe or feet comes under the steel tooth	
Wheels	Crushing injuries in between the machineframe and the rotating wheels	If a person turns the wheelframe around	Safety stickers placed Safety instructions in manual
Machine environment	Being run over by the machine and/or tractor, resulting in serious injury	If the person is between the machine and the tractor and the combination is moving (unintentionally)	Safety stickers placed Safety instructions in manual
		During transport on public roads.	
	Be knocked down by the machine, resulting in crushing injuries	If the person is next to the machine.	Safety stickers placed Safety instructions in manual
		If the person is on a slope next to the machine.	
Breathing difficulties	Danger of breathing difficulties due to dust generation during use of the machine		
Electrical voltage	Electrostatic shocks causing a shock reaction.	Depending on the weather conditions, the tires are statically loaded. In some cases, when touched, the person may be shocked.	Safety instructions in manual

ANNEX III SAFETY STICKERS

To promote safe practices and proper handling reminders, safety stickers are adhered to all machines. If a sticker cannot be read or found, it should be replaced immediately. The following page shows an overview of all the stickers and their positions.

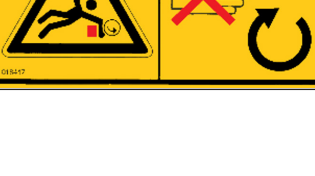
GKB001	Comply with all maintenance instructions		GKB002	Refer to the owner's manual. It contains useful information about the use, safety and maintenance	
GKB003	Regular lubrication		GKB004	Switch off the power take-off before lifting the implement	
GKB005	Risk of retraction due to rotating parts		GKB006	Risk of finger cutting due to rotating parts	
GKB007	Danger of rotating parts		GKB008	Risk of retraction due to rotating parts	
GKB009	Risk of crushing		GKB010	Keeps distance when the machine is in operation due to swinging parts	
GKB011	Keep a distance when the machine is in operation due to flying parts.		GKB012	Risk of crushing between tractor and implement	
GKB013	Danger of retraction when opening the cover when the rotor is switched on		GKB014	Choice in minimum to maximum adjustment	
GKB015	Danger of retraction due to rotating parts		GKB	Place a safety piece before entering the danger zone	
HOT	Keep a safe distance from hot surfaces		018417	Required speed	

Location safetystickers

The illustrations below show all the safety stickers and their positions:

Front view:

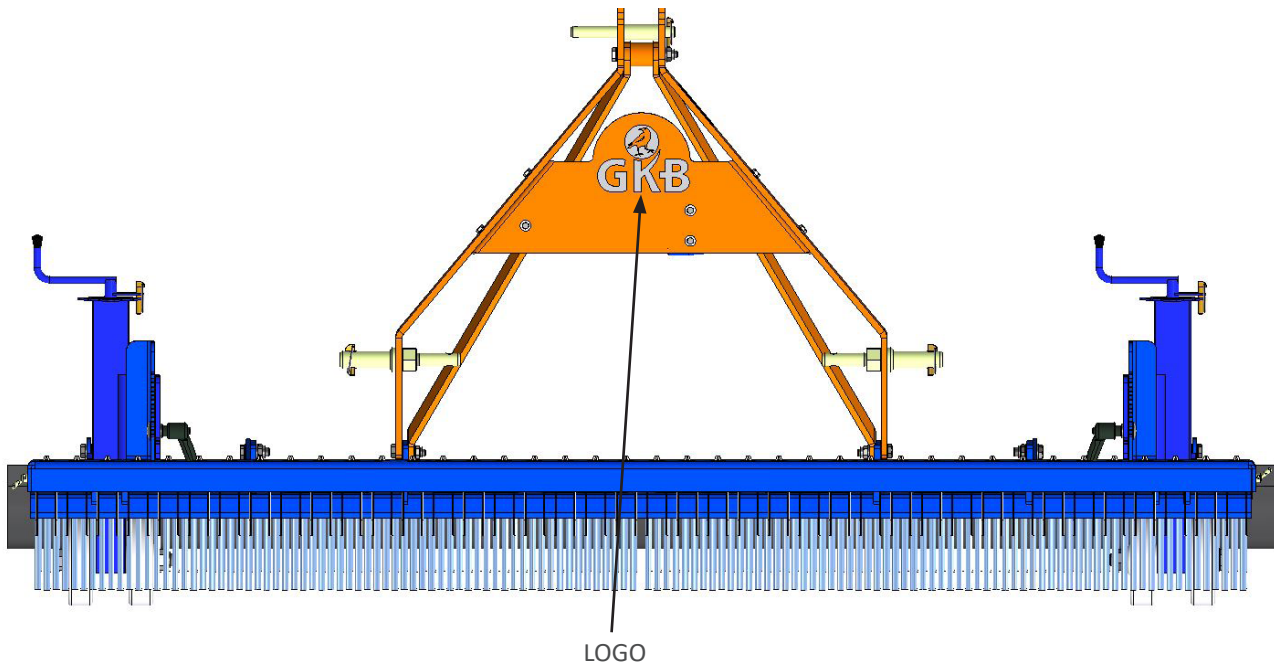

Top view:

